

# Unparalleled Sharpness

## New lens series



1/2" C-mount 20X Motorized Zoom Lens

## SLA-12240

- 20X optical zoom, 12 ~ 240mm / 0.47" ~ 9.45"
- Sharp and clear image in low light with F1.6
- F1.6 DC Type auto iris

1/2" CS-mount Varifocal Lens

## SLA-612DN

- F1.6 DC Type auto iris
- Varifocal 6 ~ 12mm / 0.24" ~ 0.47"

1/2", 1/3" C-mount 20X Motorized Zoom Lens/CS-mount Varifocal Lens

# SLA-12240/612DN



## Specifications

	SLA-12240	SLA-612DN	
CCD	1/2"	1/2"	
Iris Type	Auto Iris (DC)	Auto Iris (DC)	
Object Distance	2.8m ~ ∞	0.2m ~ ∞	
Zoom	20X	2X	
Mount	C-Mount	CS-Mount	
Focal Length	12 ~ 240mm / 0.47" ~ 9.45"	6 ~ 12mm / 0.24" ~ 0.47"	
Max. Aperture Ratio	F 1.6	F 1.6	
Angle of View	Diagonal	38.9° ~ 1.9°	86.4° ~ 38.8°
	Horizontal	30.8° ~ 1.6°	65.3° ~ 30.8°
	Vertical	23° ~ 1.2°	47.4° ~ 23°
Operation	Iris	F 1.6 ~ F 720C	Auto (F1.6 ~ 300)
	Focus	2.8m ~ ∞	Manual
	Zoom	12 ~ 240mm / 0.47" ~ 9.45"	Manual
Control	Iris	3.3V DC	-
	Focus	6 ~ 12V DC	-
	Zoom	6 ~ 12V DC	-
Back Focal Length	19.82mm / 0.78"	7.55 ~ 12.13mm / 0.3" ~ 0.48"	
Flange Back Length	17.526mm / 0.69"	12.5mm / 0.49"	
Preset	Built-in	-	
Input Signal	Video Signal (V or VS)	-	
Sensitivity Adjustment	0.5V(p-p) ~ 1.0V(p-p) (Video Signal)	-	
Operating Temperature	-10°C ~ +50°C (+14°F ~ +122°F)	-10°C ~ +50°C (+14°F ~ +122°F)	
Dimensions (WxHxD)	116 x 135 x 223.5mm (4.57" x 5.31" x 8.8")	40.4 x 45.7 x 43.5mm (1.6" x 1.8" x 1.71")	
Weight	2.6Kg (5.73 lb)	53g (0.12 lb)	

## Dimensions

Unit : mm (inch)

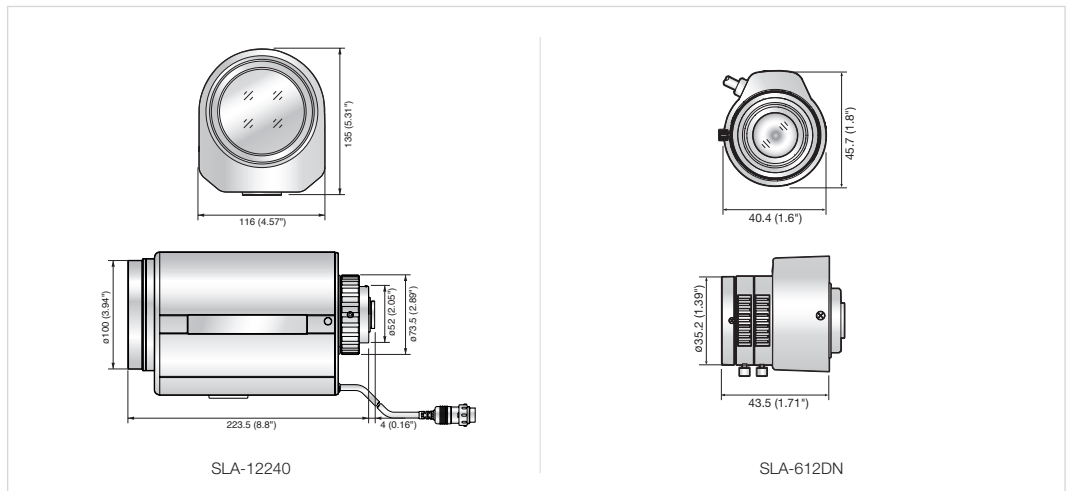

The Eco mark represents Samsung Techwin's will to create environment-friendly products, and indicates that the product satisfies the EU RoHS Directive.

Design and specifications are subject to change without notice.



### SAMSUNG TECHWIN CO., LTD.

701, Sampyeong-dong, Bundang-gu, Seongnam-si, Gyeonggi-do Korea 463-400  
Tel : +82-70-7147-8741 ~ 8749, 8752 ~ 8760 Fax : +82-31-8018-3745  
www.samsungsecurity.com www.samsungcctv.com

SAMSUNG TECHWIN AMERICA Inc.  
100 Challenger Rd. Suite 700 Ridgefield Park, NJ 07660  
Toll Free : +1-877-213-1222 Direct : +1-201-325-6920  
Fax : +1-201-373-0124  
www.samsungcctvusa.com

SAMSUNG TECHWIN EUROPE LTD.  
Samsung House, 1000 Hillwood Drive, Hillwood Business Park  
Chertsey, Surrey, UNITED KINGDOM KT16 OPS  
Tel : +44-1932-45-5300 Fax : +44-1932-45-5325

TIANJIN SAMSUNG TECHWIN OPTO-ELECTRONICS CO., LTD.  
No.11 Wei 6 Street, Micro-Electronic Industrial Park  
Jingang Road, Tianjin, P.R. CHINA 300385  
Tel : +86-22-23887788 Fax : +86-22-23887788

■ DISTRIBUTED BY

